

EZRAK® WALL MOUNT CABINET

Ideal for small office equipment

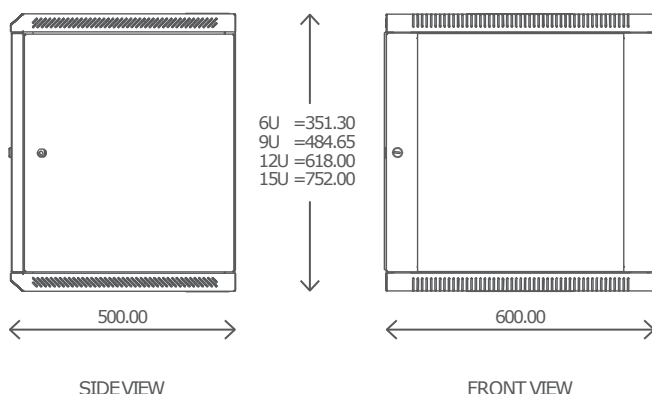
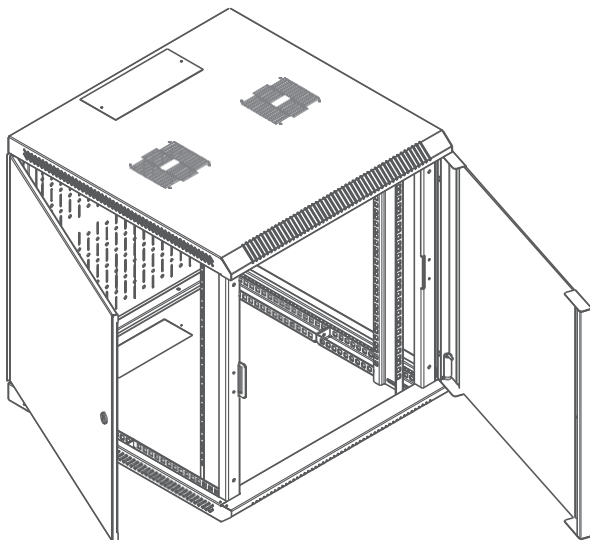

EzRak® Wall Mount

EzRak® Wall Mount cabinet has been designed to provide a solution where side access is needed during installation, service and maintenance. Cable access from top and bottom provide via removable gland plates. To ensure ventilation options, the wall box has pre-punched fan pattern at the top for up to two exhaust fans. Maximum versatility is provided with removable side panels and front door to ease installation.

FEATURES

- 4 height options – 6U, 9U, 12U and 15U Depth:
- 500mm (option 600mm)
- Width: 600mm
- Welded frame or knocked down version
- Front and side access
- Quick release reversible honeycomb perforated door
- Light weight strong construction
- Adjustable 19" panel mounts
- Load rating 40kg
- Fixing kit supplied
- Finishing: Powder Coating Black
- Other sizes available upon request
- Top Fan (optional)
- Material: 1.2mm electro galvanised steel

HEIG HT (U)	DIM#	WxD(mm) 600x500	WxD(mm) 600x600
6U	351.3	WB500-6U	WB600-6U
9U	484.6	WB500-9U	WB600-9U
12U	618.0	WB500-12U	WB600-12U
15U	752.0	WB500-15U	WB600-15U

Description	Part Number
Exhaust Fan	FT-2
19" 5 way 13A socket strip	PDU-
19" Front Mount Tray-1U	005
	FMT-1U